

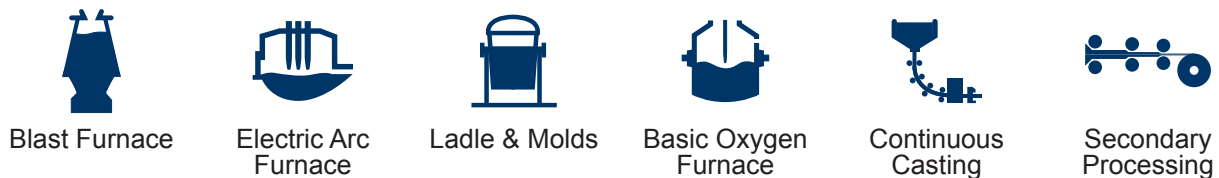

## Table of Contents

Cam and Groove .....	3
Crimp Combination Nipples, Sleeves, Ferrules.....	4
Fire Jacket.....	5
GSM Armored Hose .....	5
Dix-Lock™ / N Series Fittings .....	6
Dual-Lock / P Series Fittings .....	6
ISO B Quick Disconnects .....	7
Hydraulic Quick Disconnects.....	7
Slide Gate Couplings.....	7
Pneumatic Quick Disconnects.....	8
Hydrant Adapters.....	9
Boss™ Fittings .....	9
Band Clamps.....	10
Gauges.....	10
Flanges.....	11
Swivel Joints.....	11
Actuated Valves.....	12
Ball Valves .....	12
Hose Menders .....	13
Instrumentation Fittings .....	13
Pipe Fittings.....	13
Push-On Fittings.....	13
Rail Car Fittings.....	13
Tube Fittings.....	13
Steel Lifecycle Flowchart.....	14

### Stages of the Steel Process:



## Safety

Dixon™'s couplings and retention devices are designed to work safely for their intended use. The selection of the proper hose, coupling and retention device, and the proper application of the coupling to the hose are of utmost importance.

Users must consider the size, temperature, application, media, pressure and hose and coupling manufacturer's recommendations when selecting the proper hose assembly components. Dixon™ recommends that all hose assemblies be tested in accordance with the Association for Rubber Products Manufacturer's (ARPM) recommendations and be inspected regularly (before each use) to ensure that they are not damaged or have become loose. Visit [ARPMINC.com](http://ARPMINC.com) for more information.

Where safety devices are integral to the coupling, they must be working and utilized. The use of supplementary safety devices such as safety clips or safety cables are recommended.

If any problem is detected, couplings must be removed from service immediately.

Dixon™ is available to consult, train and recommend the proper selection and application of all fittings we sell. We strongly recommend that distributors and end users make use of Dixon™'s Testing and Recommendation Services. Call 877.963.4966 or click [dixonvalve.com](http://dixonvalve.com) to learn more.



## EZ Boss-Lock™ Cam & Groove Fittings

### Applications:

- water service connections at blast furnaces, electric arc furnaces, caster or roll mills
- acid and chemical transfer hoses on pickling lines <sup>1</sup>

### Features:

- resistant to accidental disconnection while dragging or moving
- no sliding pins to jam
- locking mechanism is fully engaged by just closing the handles
- available in custom swaged or phono-finish (PF) shank designs for hard to couple chemical hoses with thermoplastic tubes

### Materials:

- couplers and adapters: stainless steel and brass
- cam arm assemblies: investment cast stainless steel with plated carbon steel pull rings

### Sizes:

- 3/4" - 6"

<sup>1</sup> Refer to [dixonvalve.com](http://dixonvalve.com) for coupling material and gasket compatibility

 Boss-Lock™ fittings are suitable for liquid and dry material transfer only and are NOT to be used for any compressed gas or steam service.



type C coupler x hose shank



type E male adapter x hose shank



type B coupler x male NPT



type D coupler x female NPT



type A adapter x female NPT

## King Crimp™ Couplers and Adapters

### Applications:

- When used in conjunction with Dixon™ crimp fittings, ferrules create a tight seal for numerous hose applications, including those for various chemicals and temperatures.

### Features:

- when used with King Crimp™ sleeves and ferrules, creates assembly reliability
- forged brass or investment cast stainless steel handles meet chemical requirements

### Materials:

- aluminum, brass or 316 stainless steel

### Sizes:

- 1" - 6"

- Refer to our mobile app featuring the King Crimp™ calculator which allows the user to enter hose dimensions with a resulting crimp diameter and corresponding sleeve, ferrule and fitting part number all linked to the product's specification page on [dixonvalve.com](http://dixonvalve.com).

 not recommended for compressed gas, air or steam



# Crimp



## King Crimp™ Combination Nipples



### Applications:

- When used in conjunction with the Dixon™ crimp system creates a tight seal for numerous hose applications, including those for various chemicals and temperatures.

### Features:

- recommended for low-pressure discharge and suction service.
- working pressure varies with size consult Dixon™ for recommendations
- available combinations include: male NPT, beveled and grooved

### Materials:

- plated carbon steel or 316 stainless steel

### Sizes:

- 1" - 6"

---

## Crimp Sleeves



### Application:

- When used in conjunction with Dixon™ crimp fittings, sleeves create a tight seal for numerous hose applications, including those for various chemicals and temperatures.

### Features:

- wall thickness varies from .062" to .120"
- sleeve length varies from 2½" to 5½"; custom lengths available
- working pressures listed below are for 70°F and are for King Crimp™ cam and groove only, for applications or temperatures other than 70°F contact Dixon™ at 800.355.1991 for recommendations:

- 1" - \*
- 1½" - 250 PSI
- 2" - 250 PSI
- 3" - 125 PSI
- 4" - 110 PSI
- 6" - \*

\* consult Dixon™ for pressure rating

### Materials:

- stainless steel, carbon steel and aluminum

### Sizes:

- 1" - 6"; custom sizes through 12"

---

## Crimp Ferrules



### Application:

- When used in conjunction with the Dixon™ crimp system creates a tight seal for numerous hose applications, including those for various chemicals and temperatures.

### Features:

- wall thickness varies from .062" to .120"
- ferrule length varies from 2-13/16" to 5-7/8"
- working pressures listed below are for 70°F and are for King Crimp™ cam and groove only, for applications or temperatures other than 70°F contact Dixon™ at 800.355.1991 for recommendations:

- 1" - \*
- 1½" - 250 PSI
- 2" - 250 PSI
- 3" - 150 PSI
- 4" - 150 PSI
- 6" - \*
- 8" - \*

\* consult Dixon™ for pressure rating

### Materials:

- stainless steel and carbon steel

### Sizes:

- 1" - 8"

Note: King Crimp™ couplers and adapters can be found on page 3.

## Dixon™ GSM Armored Hose



### Applications:

- **Coke Battery:** pusher, quench car; **Blast Furnace:** tuyere, bosch, tap-hole drill, mud gun; **BOF:** oxygen and water cooled lance; **EAF:** shell, roof water, oxygen supply, oxy burner, natural gas, carbon lime, slag door, tilt, roof and electrode lift cylinders, EBT; ladle car, argon stir; **Caster:** mold, oscillator, segment water, hydraulic, grease, tundish, ladle slide gate; **Rolling:** reheat furnace, roll stand water, pinch roll cylinder, peel bar, walking beam, coil car and more

### Features:

- extremely flexible armor protects from heat, slag splash and harsh environments in mill applications
- heat resistant insulation to 1000°F
- temperature rating depends on specific applications, consult Dixon™
- a variety of end connections are available

### Materials:

- armor: galvanized steel or stainless steel
- inner hoses: hydraulic, stainless steel or PTFE

### Sizes:

- ¼" through 16" bore
- lengths up to 120'

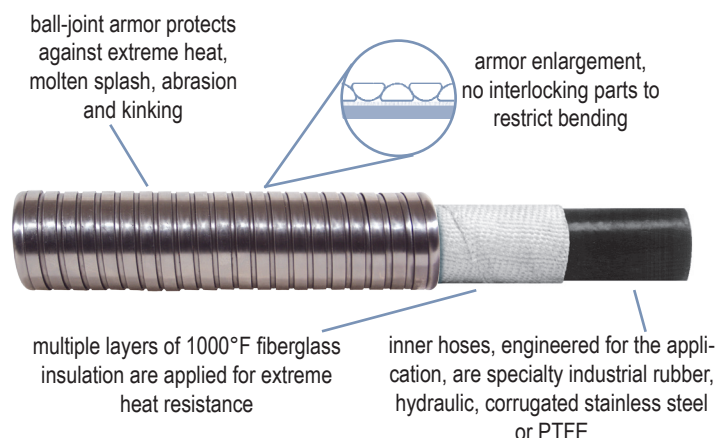
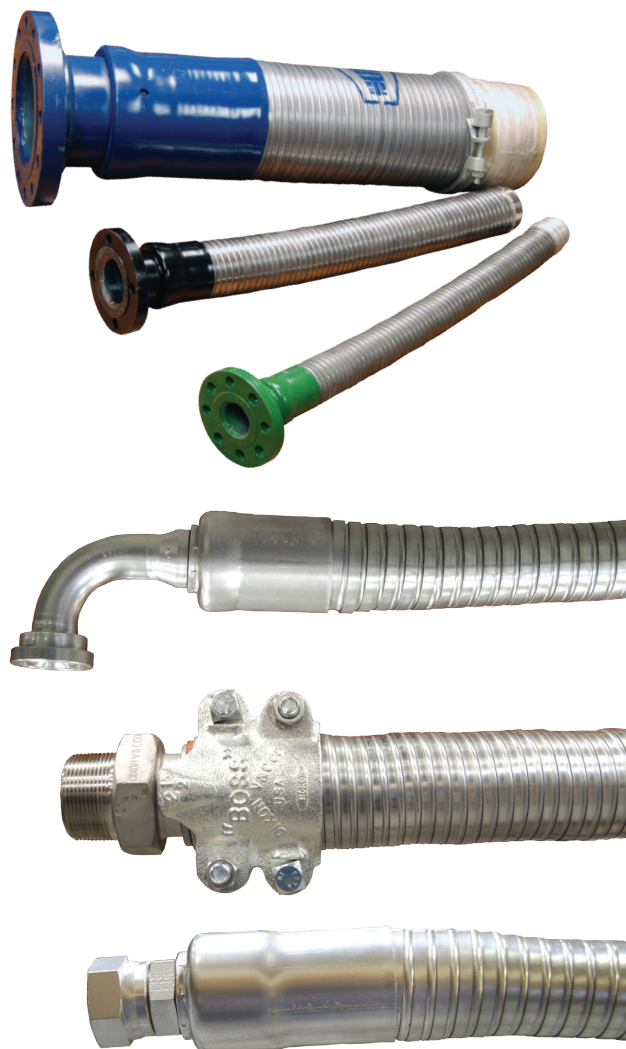

## Fire Jacket for Hose



### Application:

- Used to protect hose assemblies, tubing, piping, wiring and cables from high temperatures or molten splash

### Features:

- completely non-asbestos
- sleeving slides easily over hose and expands to go over fittings
- resistant to hydraulic fluids and lubricating oil
- helps maintain line temperatures and reduces environmental overheating and over-cooling
- color is iron oxide red
- temperature range: **-65°F to 500°F** (-54°C to 260°C)

### Materials:

- compounded silicone rubber coating over fiberglass

### Sizes:

- 50' lengths
- nominal hose ID ranges from ¼" to 4"



# Dix-Lock™ / N Series



## Dix-Lock™ N-Series Quick Acting Couplings

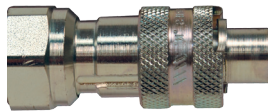

male x female NPT



female x hose shank



male x male NPT



female x female NPT

### Application:

- for in-plant use on air, water and nitrogen systems up to 300 PSI as well as pneumatic impact tools

### Features:

- interchanges with Bowes 51000, National Series B and Macdonald Quick Action
- dual-guide sleeve tabs ensure smooth action
- convenient Push-Twist and Click connection
- operating temperature range is **-40°F to +250°F**
- rated to **500 PSI** steel and stainless steel, **300 PSI** brass at ambient temperature (70°F)

### Materials:

- trivalent chrome plated steel, brass or 303 stainless steel

### Sizes:

- 3/8", 1/2", 3/4" and 1" end connections



Dix-Lock™ couplings with ferrules are also available, visit [dixonvalve.com](http://dixonvalve.com) for details.

# Dual-Lock / P Series



## Dual-Lock P Series Quick Acting Couplings

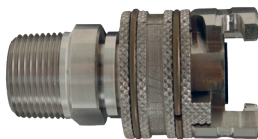

locking sleeve x male pipe thread

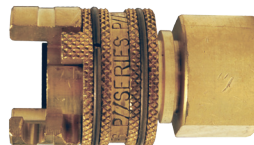

locking sleeve x female pipe thread



locking sleeve x hose barb



nipple x female thread

### Application:

- for in-plant use on air, water and nitrogen systems up to 300 PSI as well as pneumatic impact tools

### Features:

- interchanges with National Series A type and Thor PHC series couplings
- spring loaded interlocking engagement
- full flow couplings
- PM and PF series must be used with mating locking sleeve fittings
- operating temperature range is **-40°F to + 250°F**
- **300 PSI** working pressure at ambient temperature (70°F)

### Materials:

- trivalent chrome plated steel, brass and 303 stainless steel

### Sizes:

- 3/8", 1/2", 3/4" and 1" end connections

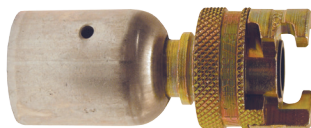

Dual-Lock couplings with ferrules are also available, visit [dixonvalve.com](http://dixonvalve.com) for details.

# Hydraulic Quick Disconnects

## Applications:

- **H Series (ISO B):** general hydraulic transfer, in-plant industrial hydraulic, construction and hand tools, and other mobile equipment, steel mills
- **K Series (ISO A):** mobile and in-plant hydraulic systems
- **V Series:** oil rigs, construction, military, general fluid transfer, in-plant industrial hydraulic

## Features:

### H Series:

- interchangeable with Parker-Hannifin 60 series and ISO 7241 Series B
- features poppet style shut-off valves in both the coupler and the plug

### K Series:

- features poppet style shut-off valves in both the coupler and the plug
- Interchangeable with the Aeroquip 5600, Parker 6600, and ISO 7241 Series A interchange

### V Series:

- V Series interchanges with Snap-tite H Series

## Materials:

- steel, brass, 303 stainless steel or 316 stainless steel
- seal: standard seal material is Buna-N
- additional materials available upon request

## Sizes:

- V series - 1/4" to 2"; H series - 1/8" - 2 1/2"; K series - 1/4" to 2"

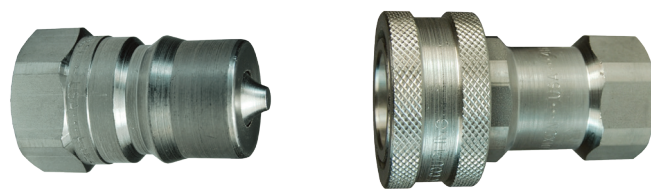

H Series



K Series



V Series

## Slide Gate Couplings

## Features:

- secure coupling resists surge flow damage commonly caused by steel mill slide gates
- easy to install
- nitrile seals are standard, providing a temperature range of **-40F° to +250F°**
- interchangeable with ISO7241 Series B
- hardened steel nipple provides heavy duty performance and resists brinelling

## Material:

- nitrile seals
- steel

## Size:

- 1/2"



## Steam Quick Disconnects

## Application:

- specially configured H Series (ISO B) couplings for saturated steam service

## Features:

- 10 to 1 safety ratio
- large diameter steel steam sleeves, available in sizes up to 1", are hardened to resist deformation and maximize service life
- steel nipples hardened to resist brinelling

## Materials:

- steel, brass or 303 stainless steel
- EPDM steam grade seals standard

## Sizes:

- 1/4" to 1 1/2"

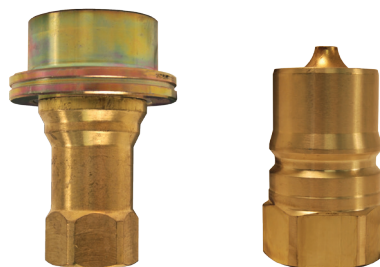

Do Not Disconnect Under Pressure!!

# Pneumatic Quick Disconnects

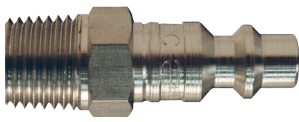

DF Series / Air Chief Industrial Interchange

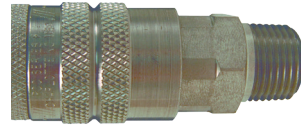

## Application:

- used to quickly connect and disconnect air hose and pneumatic tools in compressed air services

## Features:

- interchanges with MIL-C-4109F/A-A-59439
- temperature range: **-40°F to 250°F**
- rated to **300 PSI**
- couplers shut-off when disconnected
- *for pneumatic service only* 

## Materials:

- steel, brass or 303 stainless steel

## Sizes:

- 1/4" to 3/4"



M Series / Air Chief ARO Speed



## Application:

- used to quickly connect and disconnect air hose and pneumatic tools in compressed air services

## Features:

- interchanges with the ARO 210 and 310 designs
- temperature range: **-40°F to 250°F**
- rated **300 PSI** at ambient temperature (70°F)
- couplers shut-off when disconnected
- *for pneumatic service only* 

## Materials:

- steel or brass

## Sizes:

- 1/4" and 3/8"

# Flanges



## 150# ASA Forged Flanges



lap-joint



NPT threaded



lap-joint



NPT threaded



slip-on



slip-on

## Application:

- used in conjunction with pipe and welding fittings conveying water for cooling as well as oxygen and gas injection

## Features:

- lap-joint models have no raised face; commonly called a Van Stone or floating flange
- slip-on and NPT threaded models have a raised face
- bolt holes may vary with size

## Materials:

- carbon steel and 316 stainless steel

## Sizes:

- 1" to 12"

slip-on



# Hydrant Adapters



## Application:

- used in the suction and discharge of water during various segments of the steel making process

## Features:

- some models available in pin and rocker lug
- pin lugs allow for an easy connection using a standard spanner and hydrant wrench

## Materials:

- brass, polycarbonate and hardcoated aluminum

## Sizes:

- 3/4" to 6"



cam & groove adapter



reducer with pin lugs



adapter with rocker lugs

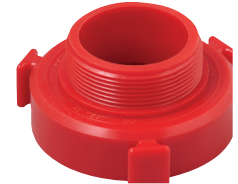

reducer with rocker lugs

# Boss™ Couplings



## Application:

- used with Boss™ Coupling System to create a secure interlocking connection ideal for elevated pressure applications such as air and steam

## Features:

- mechanical seal
- can be applied to many types of rubber, synthetic, plastic, metallic or semi-metallic hose
- two halves are connected or disconnected by rotating the wing nut onto a spud

## Materials:

- stem: 1/4" - 1" plated steel, 1 1/4" - 4" plated iron, 6" tubular steel
- spud: 1/4" - 1" plated steel, 1 1/4" - 6" plated iron
- wing nut: 1/4" - 1" plated steel, 1 1/4" - 6" plated iron
- ground joint seal: copper or polymer seats
- washer seal: Klingersil® C-4401

## Sizes:

- 1/4" to 6"



Boss complete assembly

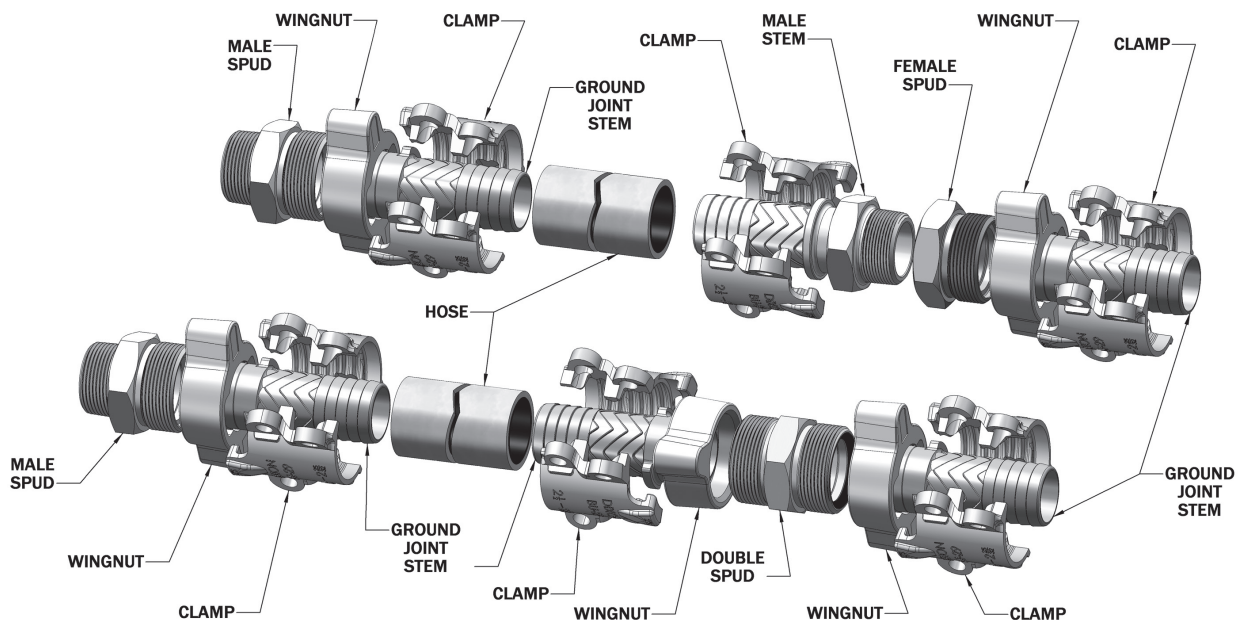

Worn-out hose couplings can be dangerous. They should be checked regularly and replaced when necessary. Each coupling user should review applications and add safety devices where indicated.



# Clamps



## Boss™ Clamps



2 gripping fingers, 4 bolt configuration

### Application:

- used with Boss™ Coupling System to create a secure interlocking connection ideal for elevated pressure applications such as air and steam

### Features:

- available in 4 bolt and 2 bolt (smaller sizes)
- available in 2 gripping fingers and 4 gripping fingers

### Materials:

- plated iron, stainless steel or brass

### Sizes:

- ¼" to 6"



- The bolts used in the Boss™ interlocking clamps are not standard bolts. These bolts can be re torqued, but it is **not** recommended that the bolts or clamps be reused, as they are designed for a single bend only.
- Torque values for clamps are based on dry bolts. The use of lubricant on bolts will adversely effect clamp performance, except with stainless steel bolts. *Do not lubricate nuts and bolts.*
- When installing stainless steel bolts and nuts, the use of anti-seize or anti-galling lubricant is advised. A light coat is required on the bolt threads to prevent thread galling and artificial torque reading.

## Band Clamps



T-bolt



Wormgear



Aero-Seal®



Pre-formed

- Visit [dixonvalve.com](http://dixonvalve.com) for more information

# Gauges



Sprinkler System Gauge



Flutterguard™ Dry Gauge



ABS Standard Dry Gauge



Liquid-Filled Stainless Steel Gauge



General Purpose Digital Gauge

# Swivel Joints



## Application:

- Used wherever a leak-proof swivel connection is needed in pipelines or in combination with hoses to eliminate hose twisting
- Industries range from petroleum, petrochemical, refining, mining, distilling, paint, farm irrigation and fertilizing, wastewater treatment plants and food and beverage process equipment. Dixon™'s swivel joints are found in blending plants, drum filling applications, fluid and dry bulk transfer, vacuum trucks, oil and gas trucks and water trucks. Larger swivels can be found in the steel industry, marine bulk transfer and many more.

## Features:

- full 360° rotational movement
- wide spacing between dual ball bearing raceways ensures greater load bearing capacity
- precision-machined design ensures alignment and years of trouble-free service
- O-ring dust seal protects the ball races and seals chamber from outside elements
- radius elbow design ensures a smooth flow pattern
- hydrostatic testing is performed on all swivels before shipment

## Options Available:

- end configurations: female NPT, 150# flanges, TTMA flange, grooved, weld end and many other variations
- seal options: Buna, FKM, PTFE, EPDM, FDA Buna, FFKM
- ball bearing materials: carbon steel, 440 stainless steel, and 316 stainless steel
- grease materials: Lithium, FDA approved/food grade and silicone
- swivels that include oxygen, steam or submerged service can be specifically designed for unique applications (special order)
- 100% full penetration weld
- re-build kits available
- custom swivel options available, contact Dixon™ at 888.226.4673



## O-Ring Parts Identification List

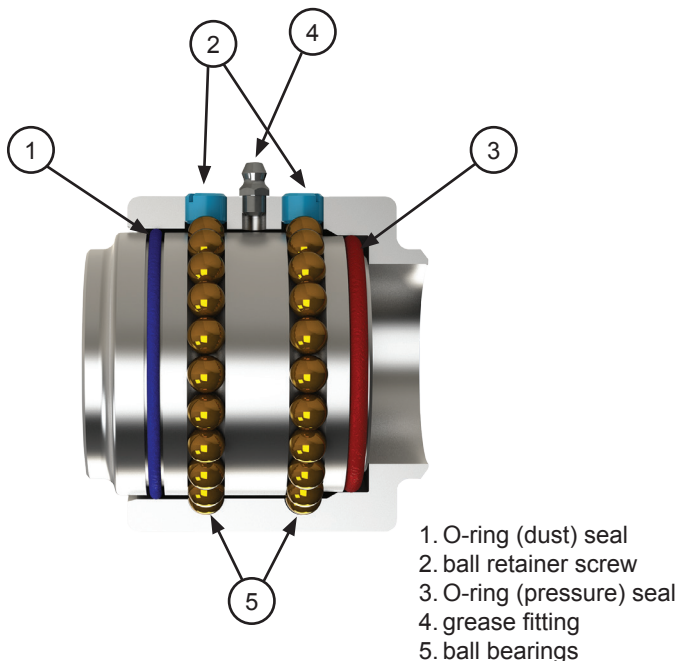

## O-ring Features:

- sizes: 1"-4"
- O-ring pressure seal ensures a leak-proof seal and smooth rotation with lower torque.
- available working pressure ratings up to 1000 PSI
- available in carbon steel, 316L stainless steel, aluminum, brass and malleable iron

## V-Ring Parts Identification List

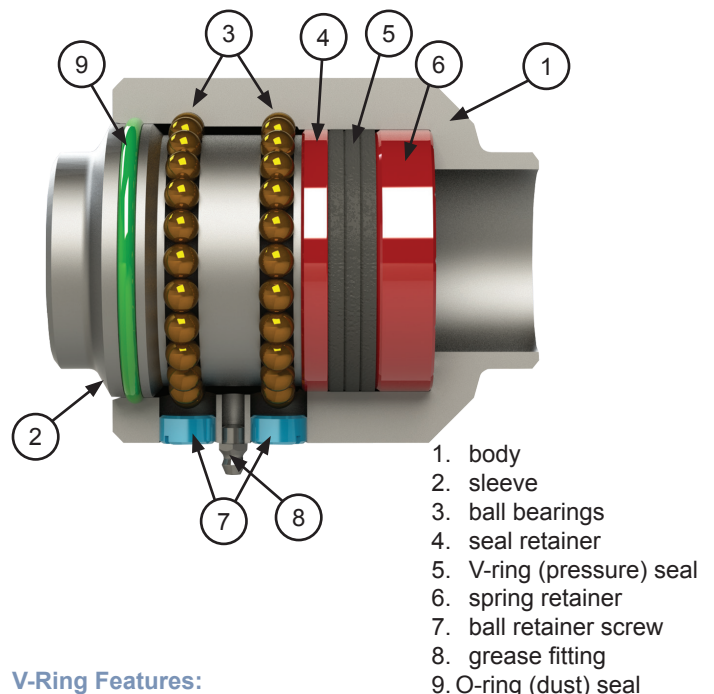

## V-Ring Features:

- 2"-12" size range
- spring loaded triple V-ring sealing system ensures a leak-proof seal at either high or low pressure and extends seal life
- available working pressure ratings up to 1000 PSI
- available in carbon steel, 316L stainless steel and limited aluminum



## Actuated Ball Valves

### Pneumatically Actuated



3 piece ball valve

#### Application:

- used in the automated control of oil, gas and other liquids through pipe lines

#### Features:

- operating temperature range: **-40°F to +200°F**
- 80 PSI plant air required for actuator
- visual position indication
- available in 2-piece, 3-piece, double acting and 3 way configurations

#### Actuator Materials:

- body: hard anodized aluminum
- O-rings: Buna-N

#### Valve Materials:

- body and ball: CF8M
- blow-out proof stem: stainless steel
- seats: 15% glass reinforced RTFE

#### Sizes:

- 2", 3", 4" and 6"

---

### Electrically Actuated



3 piece ball valve

#### Application:

- used in the automated control of oil, gas and other liquids through pipe lines

#### Features:

- working temperature: **-41°F to 140°F**
- extended duty cycle induction motor
- visual position indication
- manual override standard: 1/2" - 1 1/2"
- space heater is standard
- NEMA 4/4X waterproof and dust proof
- available in 2-piece, 3-piece, double acting, and 3 way configurations

#### Actuator Materials:

- housing: lightweight powder coated aluminum alloy
- gear train: high alloy steel

#### Valve Materials:

- body and ball: CF8M
- seat: 15% glass reinforced RTFE
- blow-out proof stem: stainless steel

#### Sizes:

- 2", 3", 4" and 6"

## Ball Valves



### Domestic Full Port Brass Ball Valves

**Application:**

- for control of air, water, oil and gas in pipe lines

**Features:**

- blow-out proof stem design
- rated to 600 PSI WOG; 150 PSI saturated steam
- vacuum service to 29 inches Hg
- full port design

**Materials:**

- ball: machined solid chrome-plated
- castings: bronze
- seats and seals: multi-fill PTFE

**Sizes:**

- 1/4" - 4"



### 250 Lb. Steam Ball Valves

**Application:**

- for control of air, water, oil, gas and steam in pipe lines

**Features:**

- blow-out proof stem design
- rated to 600 PSIG; 250 PSI saturated steam
- vacuum service to 29 inches Hg
- maximum temperature rating 406°F
- standard port design

**Materials:**

- threaded valve: bronze
- ball and stem: 316 stainless steel
- stem packing: high-temperature MTFE
- seats and box ring: multi-filled RPTFE

**Sizes:**

- 1/2" - 2"



## Also Available



Fire Equipment



Washdown



Maintenance and Repair

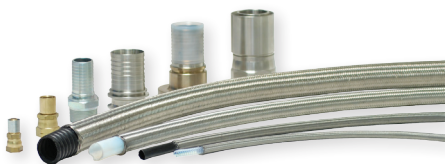

PTFE



Shank and Water



Pipe Fittings

# The Steel Life Cycle

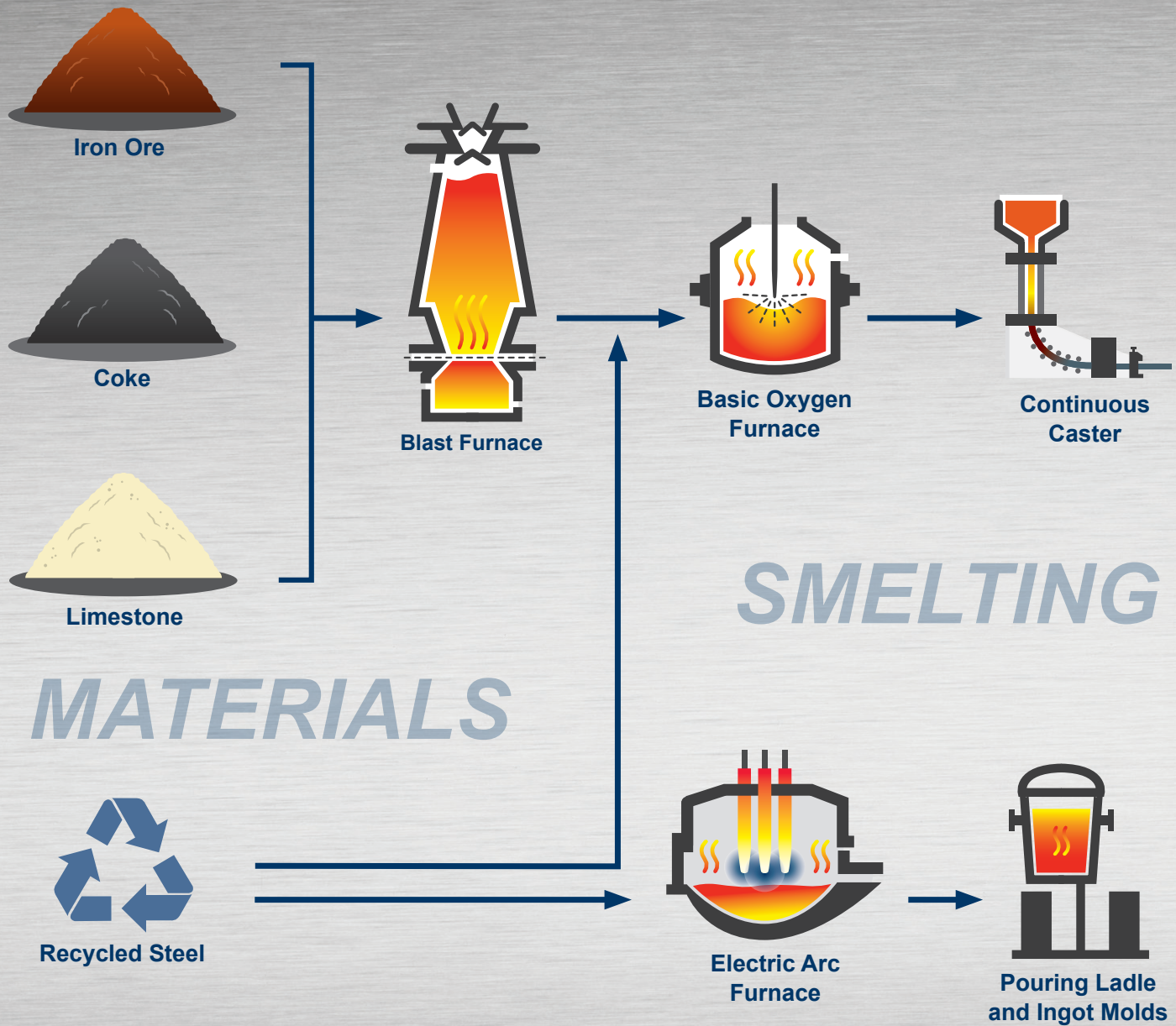

*Dixon™ has a product for every process of the steel industry*

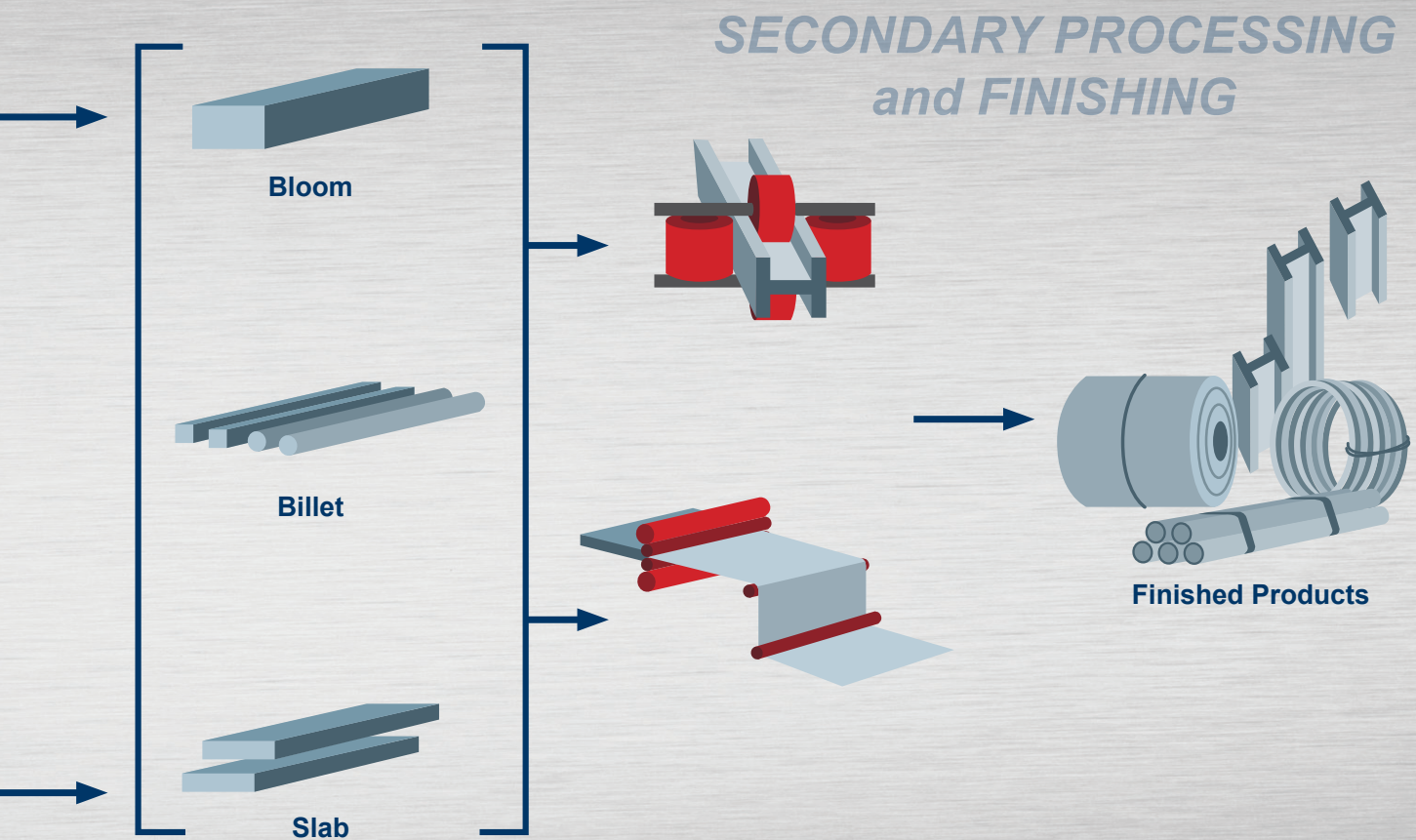

*The Right Connection®*

Dixon™, founded in 1916, is a premier manufacturer and supplier of hose couplings, valves, dry-disconnects, swivels, and other fluid transfer and control products. The company's global reach includes a wide range of products for numerous industries including petroleum exploration, refining, transportation, chemical processing, food & beverage, steel, fire protection, construction, mining and manufacturing. Dixon™'s strategic objective is to create solutions that make products safer, leak-free, longer lasting, and always available.

**dixonvalve.com • Customer Service: 877.963.4966**



*The Right Connection®*

**Dixon Valve**

800 High Street, Chestertown, MD 21620

ph: 877.963.4966

fx: 800.283.4966



Dixon  
Customer Service