

Petrochemical Life Cycle ① *Exploration and Production*

The content in this phase of the Petrochemical Life Cycle (see pages 22-23) is focused on the numerous transfer applications in the oil and gas field. Featured are the Dixon® products used within the Exploration / Production segment.

Please refer to the Dixon® Price List or dixonvalve.com for specific part numbers and various other products used in the transfer and control of liquids, gases and dry materials.

Table of Contents

Boss™ Low Pressure System Products Introduction	3
Water Supply Fittings	4
Frac Fittings	5-6
One-Piece and Two-Piece Hammer Union Nuts, Caps, Plugs	7-8
Flange Adapters	9-10
Positive Displacement Pumps	11
Butterfly Valves	12
Intake Manifolds and Assemblies	13
Cam & Groove and Abrasion Resistant Inserts	14
Vent-Lock™ Safety Cam & Groove	15
EZ Boss-Lock™ and King Crimp™ Couplers	15
GSM Armored Hose and King™ Safety Cables	16
Dry Disconnects	17
Safety Breakaways	17
Hydraulic Quick-Disconnects	18-20
Hydraulic Adapters	21
Air & Water Utilities	21
Petro-Chemical Lifecycle	22-23

Safety

Dixon®'s couplings and retention devices are designed to work safely for their intended use. The selection of the proper hose, coupling and retention device, and the proper application of the coupling to the hose are of utmost importance.

Users must consider the size, temperature, application, media, pressure and hose and coupling manufacturer's recommendations when selecting the proper hose assembly components. Dixon® recommends that all hose assemblies be tested in accordance with the Association for Rubber Products Manufacturers (ARPM) recommendations and be inspected regularly (before each use) to ensure that they are not damaged or have become loose. Visit ARPMINC.com for more information.

Where safety devices are integral to the coupling, they must be working and utilized. The use of supplementary safety devices such as safety clips or safety cables are recommended.

If any problem is detected, couplings must be removed from service immediately.

Dixon® is available to consult, train and recommend the proper selection and application of all fittings we sell. We strongly recommend that distributors and end users make use of Dixon®'s Testing and Recommendation Services. Call 877.963.4966 or click dixonvalve.com to learn more.

BOSS™ LPS Products

Low Pressure Systems

Dixon® is committed to understanding customer challenges and developing solutions. Key to achieving these objectives is Dixon®'s Innovation Center, an engineering, research and training facility integral in the development of the Boss™ LPS products defined in this brochure.



Visit dixonvalve.com/history to learn more.

Hydraulic Fracturing Site

Boss™ LPS (Low Pressure System) products are used in many of the applications found at hydraulic fracturing sites from the water source up to high pressure pumps. Please refer to the following pages for detailed information on Dixon®'s expanding product line.

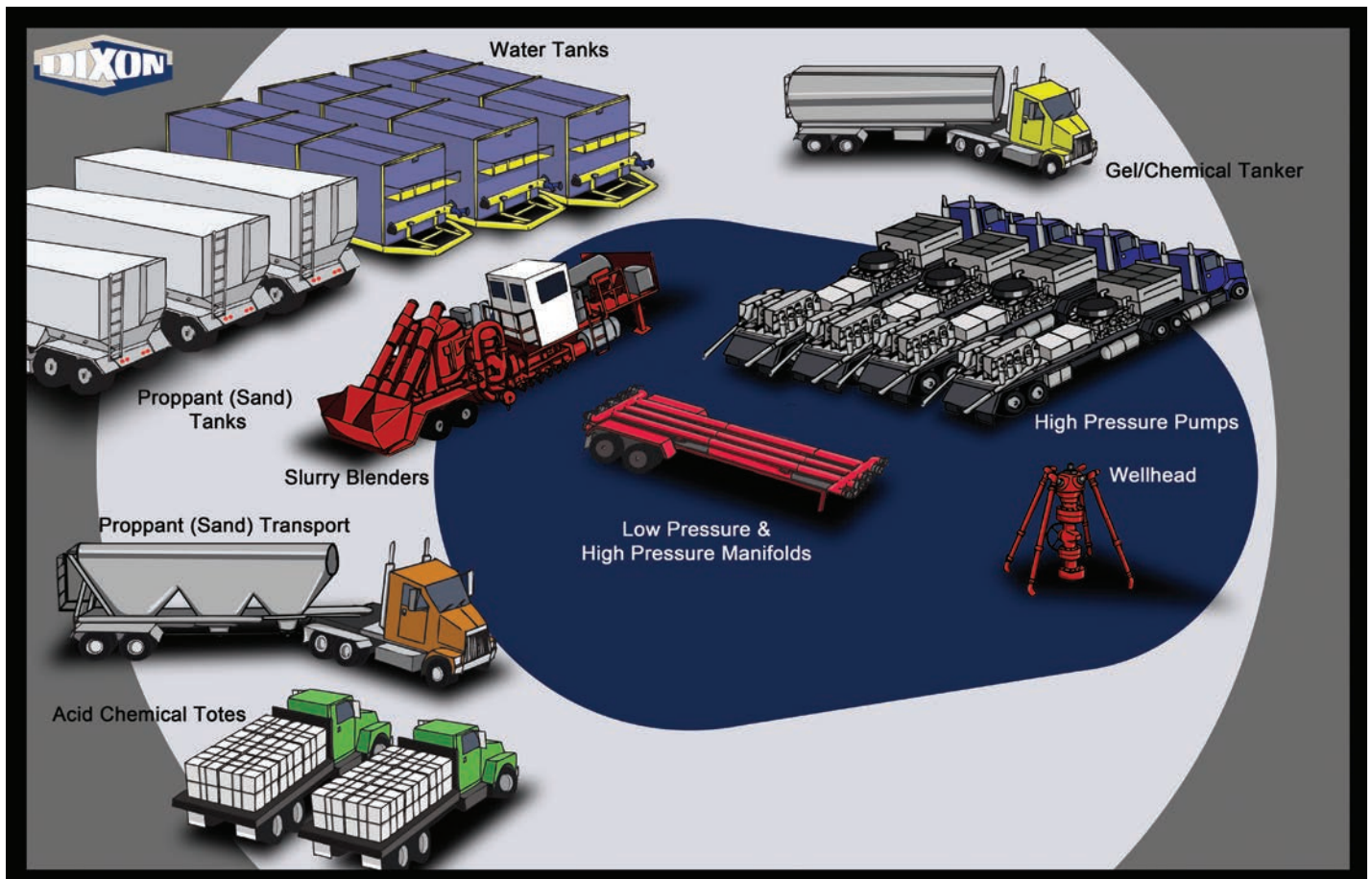

King Crimp™ Style Short Combination Nipples, Ferrules and Sleeves



STC80CS
S900X400X120CS
CFS800-1CS

Application:

- recommended for low-pressure discharge and suction service for compatible liquids

Size:

- 8"

Material:

- schedule 40 plated carbon steel to ASTM standards

Features:

- short combination nipples, ferrules, sleeves

Approval:

- materials meet ASTM standards

Grooved and NPT Threaded End King™ Combination Nipples



STV100



STC120

Application:

- recommended for low-pressure transfer and suction service for compatible liquids

Sizes:

- ½" through 12"

Materials:

- unplated steel and plated steel

Features:

- crimp sleeves are available and recommended for reliable assemblies
- compatible sleeve recommendations are available, call 877.963.4966

Specification:

- grooved ends, NPT threaded end

Special Sleeve and Ferrule Part Numbering System

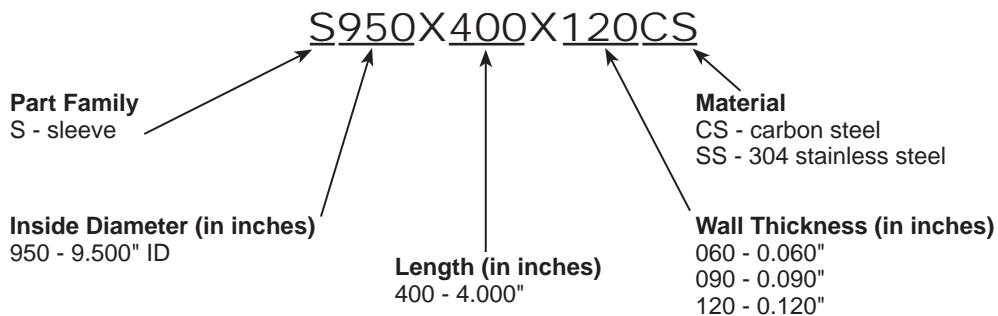

One-Piece Dixon® Frac Fittings

Application:

- used in the transfer of water, chemicals and sand slurry at hydraulic fracturing sites

Sizes:

- 1", 2", 3", 4", 6" and 8"

Materials:

- frac fittings: machined iron to ASTM standards; all stems zinc plated
- male 3", 4" and 6" NPT steel fittings are schedule 80 pipe; 8" NPT fittings are schedule 40 pipe
- O-rings Buna-N

Features:

- one-piece stem design eliminates leak path experienced with two-piece threaded systems
- interchangeable with reliable brands

Specifications:

- 400 PSI (28 BAR)** working pressure at **70°F (21°C)** for 3" and 4" sizes; 4:1 safety factor (SF)¹
- 150 PSI (10 BAR)** working pressure at **70°F (21°C)** for 6" size; 4:1 safety factor (SF)
- 150 PSI (10 BAR)** working pressure at **70°F (21°C)** for 8" size; 3:1 safety factor (SF)
- Buna-N O-ring temperature rating **-40°F (-40°C) to 250°F (121°C)**
- figure 100 and 206 female and male frac fittings, male NPT fittings



Approvals:

- all sizes meet ASTM standards

¹ 400 PSI (28 BAR) working pressure with a minimum 4:1 safety factor (*hose burst: hose working pressure*) is only achieved with:

- 3" size uses standard crimp ferrules
- 4" size requires heavy duty (HD) crimp ferrules, CF400-6CSHD through CF400-16CSHD

Note: Water and petroleum transfer hoses rated from **100 to 300 PSI (7 to 21 BAR) WP (4:1 SF)** have excellent test results with the standard King Crimp™ ferrules *CF400-xxCS*.



HUF206400CS



HUM206400CS



STC40CSHD

Figure 206 Frac Fittings (316 stainless steel)

Application:

- used in the transfer of water, chemicals and sand slurry at hydraulic fracturing sites

Sizes:

- 1", 2" and 4"

Materials:

- frac fittings: 316 stainless steel
- O-rings: 1" and 2" with FKM; 4" with Buna-N

Features:

- one-piece stem design eliminates leak path experienced with two-piece threaded systems
- interchangeable with reliable brands

Specifications:

- 400 PSI (28 BAR)** working pressure at **70°F (21°C)**; 4:1 safety factor (SF)¹
- figure 206 female and male



¹ 400 PSI (28 BAR) working pressure with a minimum 4:1 safety factor (*hose burst: hose working pressure*) is only achieved with: 4" size requires heavy duty (HD) crimp ferrules, CF400-6CSHD through CF400-16CSHD, heavy duty SS are not available



RHUM206100CS-1



RHUF206100CS

Suction Service Fittings



HUSF500SW



HUSM500SW1



beveled end
STB50

Application:

- used in the transfer of dry cement, and in mud system suction lines

Size:

- 5"

Materials:

- unions and hose fittings: carbon steel
- nuts: 2-piece forged steel, figure 50 split nuts located on opposite page

Features:

- socket weld male and female unions for attaching to hose fittings or pipe
- weld ready hose fittings available from Dixon®
- 2-piece nut is pinned and bolted for easy service and repair
- figure 50 suction hose fittings

Specifications:

- available configurations: socket weld x suction male hammer union, socket weld x suction female hammer union, King™ combination nipple, figure 50 suction hammer union split nut (includes bolts)

Approvals:

- nuts meet AISI standards

Hammer Unions



HU100400



HU206200

Application:

- used in the transfer of water, chemicals and sand slurry at drilling and hydraulic fracturing sites

Sizes:

- 100 series: 2", 2½", 3", 4", 6" and 8"
- 200 / 206 series: 1", 1½", 2", 2½", 3", 4", 6" and 8"

Materials:

- 100 series: steel
- 200/206 series: forged steel

Features:

- 100 series: threaded and buttweld ends available
- 200 / 206 series: nitrile O-ring mounted fitting body
- visit dixonvalve.com for availability of other HU series hammer unions

Specifications:

- 100 series: used on low pressure manifolds and lines in applications running air, water, oil or gas up to **1,000 PSI (69 BAR)** non-shock cold working pressure
- 200 series: used in general service applications running air, water, oil or gas up to **2,000 PSI (138 BAR)** non-shock cold working pressure

One-Piece Hammer Union Nuts

Application:

- used with any hammer union fittings requiring reliable nuts

Sizes:

- 1", 2", 3", 4", 6" and 8"

Material:

- forged steel meeting AISI standards

Features:

- long lasting and dependable nut
- all nuts are interchangeable with reliable brands
- 6" and 8" sizes have a 4 lug design for more surface area to hammer

Specifications:

- 2,000 PSI (138 BAR)** cold working pressure
- available configurations: figure 100 forged wing nut, figure 206 forged wing nut

Approval:

- nuts meet AISI standards



HU206400N



HU206800N

Two-Piece Hammer Union Nuts

Applications:

- replacement for damaged hammer union nuts
- used with male one-piece flange adapters

Sizes:

- 4", 5", 6" and 8" (bolts included)

Material:

- forged steel meeting AISI standards

Features:

- lug design provides enlarged surface area to hammer
- repair nut is pinned and bolted for perfect alignment
- all split nuts have chamfer for welding
- nut can be installed on pre-existing hammer union assembly
- 4" Figure 200/206 nut is interchangeable with reliable brands
- 5" Figure 50 nut is interchangeable with reliable brands
- 6" and 8" Figure 100/200/206 nuts are interchangeable with reliable brands

Specifications:

- 2,000 PSI (138 BAR)** cold working pressure
- available configurations: figure 200/206 split nut (in blue or black), suction hammer split nut, other configurations available

Approval:

- nuts meet AISI standards



HU200800RN



HUS500RN

Dixon® recommends using Loctite® Threadlocker Red 271™ when bolting together two-piece hammer union nuts to ensure that bolts do not loosen when in service. Option two is to weld the seams of the split nut. Bolt torque recommendation is 60 foot pounds.



Figure 206 Caps

Application:

- prevents leakage of hydraulic fracturing fluids from hammer union connections used on manifolds and hose assemblies; equipment can be in pressurized service or in transit to an alternate location

Sizes:

- 2", 4"
- 5" available with 2-piece nut

Materials:

- bull plug: iron to ASTM standards
- nut: forged steel meeting AISI standards
- bolt: Grade 8 carbon steel

Features:

- low profile design for tight applications
- designed with reusable bull plug to rebuild cap
- includes a threaded bolt hole for attaching chain or cable
- chain: welded Grade 30 steel is zinc plated for longer life

Specification:

- bull plug style cap assembly contains: figure 206 nut, bull plug body, retaining ring

Approvals:

- bull plug meets ASTM standards
- nut meets AISI standards



HUC206400

Figure 207 Caps and Plugs



HUC207400

Application:

- prevents leakage of hydraulic fracturing fluids from hammer union connections used on manifolds and hose assemblies; the fracking equipment can be in pressurized service or in transit to an alternate location

Size:

- 4"

Materials:

- caps and plugs: forged steel meeting AISI standards
- bolt: Grade 8 carbon steel

Features:

- caps and plugs are produced of forged steel to ensure longevity, reliability and performance
- cap is designed with larger lugs for easier installation and disassembling
- cap design includes a threaded bolt hole for attaching chain or cable
- plug is designed with larger handle for easier installation and disassembling
- D-ring Clevis for plug is 316 stainless steel
- plug design includes a handle hole to attach chain or cable
- optional chain made of welded Grade 30 steel and zinc plated for longer life

Approvals:

- caps and plugs meet AISI standards



HUP207400

One-Piece Flange Adapters

Application:

- used in the transfer of water, brine, water-based chemicals, water-based acids, and gelatinous proppant (sand) slurry at hydraulic fracturing sites

Sizes:

- 4" and 8" with 125 lb. flanges (150 lb. bolt hole pattern ¹)
- 4" and 8" with butterfly valve flange dimensions ²

Materials:

- adapters: iron meets ASTM standards
- nuts: forged steel to AISI standards

Features:

- no welds or pipe threads to deteriorate causing premature leakage
- two-piece nut is pinned and bolted for perfect alignment
- all 4" and 8" Figure 206 threads are interchangeable with other reliable brands
- all 4" and 8" flanges are compatible with other reliable brands with 150 lb. ¹ or butterfly flange ² bolt hole patterns

Specifications:

- flange x female or male hammer union straights (standard or short length)
- 45° elbows in female and male (flange x hammer union)
- 60° and 80° elbows with two-piece nuts (male x female)

Approvals:

- adapters meet ASTM standards
- nuts meet AISI standards



HUF206400FLG



HUM206400FLG



HUM206400FLG-1



HUF206400FLG-45



HUMF20640060



HUMF20640080

150 lb. Flange ¹

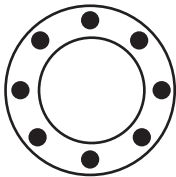

Butterfly Valve Flange ²

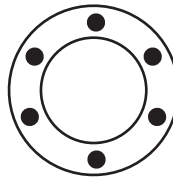

HUHA-4



HUHA-5



4FAMT



4HFAV
flange x groove

Part numbers, 2D drawings and additional information can be found at dixonvalve.com

One-Piece 150 Lb. Flange to Weld Adapters

Application:

- used on a 12" pipe manifold to transfer water, brine, water-based chemicals, water-based acids or gelatinous proppant (sand) slurry at hydraulic fracturing sites

Sizes:

- 7½" and 10½" standard lengths

Material:

- weldable cast steel, grade A

Features:

- no welds or pipe threads to deteriorate causing premature leakage
- easy to weld to 12" pipe manifolds
- formed butt weld provides accurate alignment

Specification:

- available pattern: 1-hole, 2-hole

Approvals:

- adapters meet ASTM standards

1-Hole Pattern

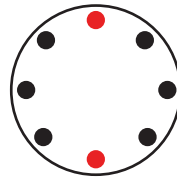

2-Hole Pattern

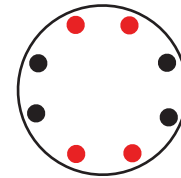

WA4FL12X750-1



WA4FL12X1050-1

Figure 206 Female Port Adapters

Application:

- adapter and cap used with 3-port and 5-port intake manifolds that feed proppant slurry to HHP pumps used in hydraulic fracturing

Size:

- 2"

Materials:

- nut: forged steel nut meeting AISI standards
- female adapter: iron
- bull plug: iron
- bolt: Grade 2 carbon steel

Features:

- low profile design for tight applications
- designed with reusable bull plug to rebuild cap
- female adapter with wrench flats for ease of installation
- optional cable is galvanized carbon steel with aluminum ferrules for longer life

Approvals:

- steel adapters meet AISI standards
- iron bull plug meets ASTM standards



HUC206200



HUF206200MT

Positive Displacement Pumps

Application:

- accurately transfer liquid additives to the blender that produces slurry used in hydraulic fracturing operations

Materials:

- all wetted parts: 316L stainless steel
- elastomer seals: EPDM, Buna-N, FKM

Features:

- front loading seals allow for fast and easy maintenance
- stainless steel gear box standard
- male NPT port connections standard
- base plate adapters available to mate with OEM pump foot print
- hydraulic motor adapter housing that can be used multiple times when replacing pump
- other adapter mounting plates available to fit unique applications
- one pump that handles various flow rates



Size	Part #	Description
1½"	<i>RZL115-FRAC2-A</i>	Pump with adapter housing to connect with SAE-A hydraulic motors
	<i>RZL115-FRAC2-B</i>	Pump with adapter housing to connect with SAE-B hydraulic motors



Dixon® Butterfly Valves

Applications:

- low pressure transfer of water, acids, chemicals, slurries and other liquids
- designed for all low pressure hydraulic fracturing applications

Size:

- 4"



4BF416DITF-NBR

Materials:

- body: ductile iron
- disc: ductile iron with Buna-N seat (-20°F to 200°F), or FKM seat (0°F to 200°F)
- bushings: PTFE
- O-rings: Buna N
- stems: 416 stainless steel
- retainer pins: 302 stainless steel

Features:

- locators around the outer edge of the body allow the valve to easily line up at center
- thicker stems compared to other brands delivers a more durable and reliable performance
- 10 position throttling handle for control accuracy
- for use between two butterfly valve flanges

Specification:

- typical gauge pressures in transfer applications range from **50 to 200 PSI** working pressure (MSS SP-67 spec)

Ductile Iron Butterfly Valves

Application:

- controls flow of water, chemicals and sand slurry

Sizes:

- 2", 3", 4", 6" and 8"

Materials:

- body: ductile iron, ASTM A536
- disc: nickel plated ductile iron
- top and bottom stems: 416 stainless steel
- seal and stem seals: Buna-N
- bushing: PTFE

Features:

- will lock "open" or "closed"
- for use between two 150 lb. flanges
- number of holes on the valve depends on the body size

Specification:

- rated to **200 PSI**



IBFVW400



NOT RECOMMENDED FOR STEAM SERVICE

3 and 5 Port Intake Manifolds

Application:

- used in the transfer of water, brine, water-based chemicals, water-based acids, and gelatinous proppant (sand) slurry used at hydraulic fracturing sites

Size:

- 6" intake

Materials:

- iron meeting ASTM standards
- O-rings: Buna-N

Features:

- manifold designed for efficient fluid flows and reduction of pump cavitation caused by sand fallout
- single cast unit with no welds to deteriorate causing premature leakage/failure
- side ports designed for easy pump cylinder inspection
- reduced height for ease of installation
- bolt hole pattern on manifold base plate available for the Weir SPM and Gardner Denver stimulation frac pumps

Specifications:

- 6" male NPT manifold with six 2" female NPT ports, one 1" NPT port
- 6" grooved manifold with six 2" female NPT ports, one 1" NPT port
- O-rings and screws included with all configurations
- weight: 3 port - 162 lbs.
5 port - 187 lbs.
- Patented

Approval:

- iron meets ASTM standards

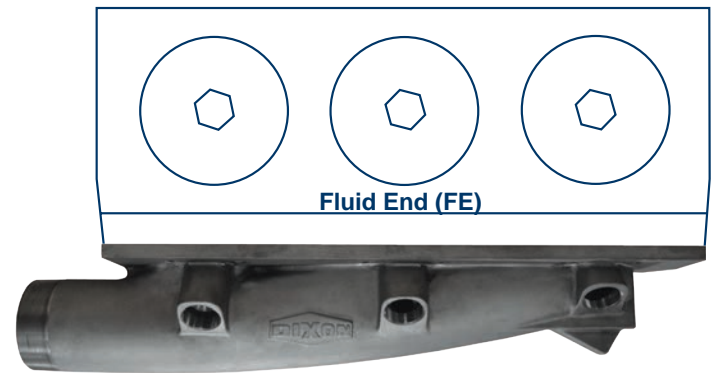

3PORTM-6T

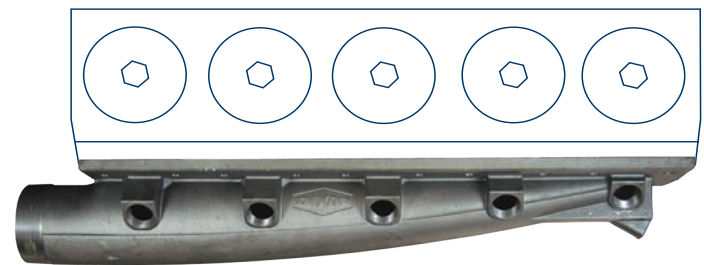

5PORTM-6T-W

5 Port Intake Manifold Assemblies

Specifications:

- bill of materials for assembly 5PM6TW-S5C:
 - 5PORTM-6T-W manifold for Weir SPM pump
 - HUF206200MT 2" figure 206 female hammer union adapter, sealed
 - HUC206200 2" figure 206 bull plug style cap
 - HUBT716X100 bolt 7/16"-14 by 1" long, Grade 8
 - CABLE18 has cable length of 18"
 - HU206600 6" steel hammer union, threaded, sealed
 - SHP100 1" MNPT square head plug, 150# iron, hand tight
 - SHP200 2" MNPT square head plug, 150# iron, hand tight
 - HHBT875X175 bolt 7/8" - 9 by 1 3/4" long, Grade 8
 - O439BU Buna-N O-ring



5PM6TW-S5C

Part numbers, 2D drawings and additional information can be found at dixonvalve.com

Cam & Groove



400-C-MI

Application:

- used as fittings for sand and ceramic proppants (material that keeps an induced hydraulic fracture open following a fracturing treatment)

Sizes:

- 1½", 2", 3", 4" and 6"

Materials:

- unplated, plated malleable iron or ductile iron

Specification:

- adapters also available, visit dixonvalve.com for more information



400-E-MI

Abrasion Resistant Inserts

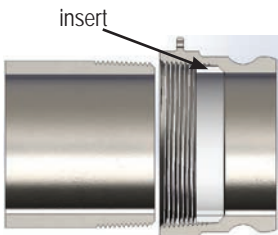

Application:

- extends the life of adapters and couplers when transferring proppant to storage tanks

Size:

- 4"

Materials:

- insert: UHMW polyethylene
- adapter: aluminum, brass, iron and stainless steel
- coupler: aluminum and malleable iron



400-A-BRINSERT

Features:

- abrasion resistance extends service life
- available for multiple adapter materials including aluminum, brass, malleable iron and stainless steel
- available for multiple coupler materials including aluminum and malleable iron

Specifications:

- adapter x female NPT with insert, coupler x hose shank with insert



400-C-MIINSERT

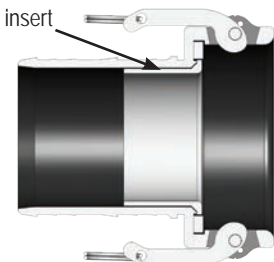

Part numbers, 2D drawings and additional information can be found at dixonvalve.com

Vent-Lock™ Safety Cam & Groove

Application:

- transfer of fluids and solids, with a safer disconnection

Sizes:

- 1", 1½", 2" and 3"

Materials:

- 316 stainless steel
- other materials to be available, contact Dixon®

Features:

- permits the release of static pressure when disconnecting hose assemblies
- venting system protects operator from being sprayed with hazardous or non-hazardous fluids or solids
- does not interchange with standard cam and groove products, use only with Dixon®  L-style fittings
- safety orange cam arms
- attachment options: ferrules, sleeves, bands, and other reliable options

Specifications:

- rated to **250 PSI**, recommendation based on the use of mating Dixon® L-style fittings at ambient temperature **70°F (21°C)** with standard Buna-N seal installed, for use at elevated temperature or other unusual operating conditions, consult Dixon®
 - 1", 1½" and 2" sizes have a maximum working pressure of **250 PSI**
 - 3" maximum working pressure **150 PSI** with King Crimp™ ferrules, crimp sleeves and bands at **125 PSI**
- adapter x female NPT, coupler x hose shank, adapter x hose shank, dust cap, dust plug



EZ Boss-Lock™ Cam & Groove

Applications:

- suitable for water, chemical, acid, and crude transfer as well as other petrochemical applications

Sizes:

- 1" - 6"



Material:

- 316 stainless steel

Features:

- positive lock handles - prevent accidental uncoupling
- handles lock automatically when closed

Specifications:

- working pressures are available, call Dixon® or visit dixonvalve.com for information
- coupler x male NPT, coupler x hose shank, coupler x female NPT, dust cap
- not recommended for compressed gas, air or steam 
- under no circumstances should the EZ Boss-Lock cam arms be used on any fitting not specifically designed for their use 



Note: Our complete line of cam and groove products can be viewed at dixonvalve.com.

Part numbers, 2D drawings and additional information can be found at dixonvalve.com

GSM Armored Hose

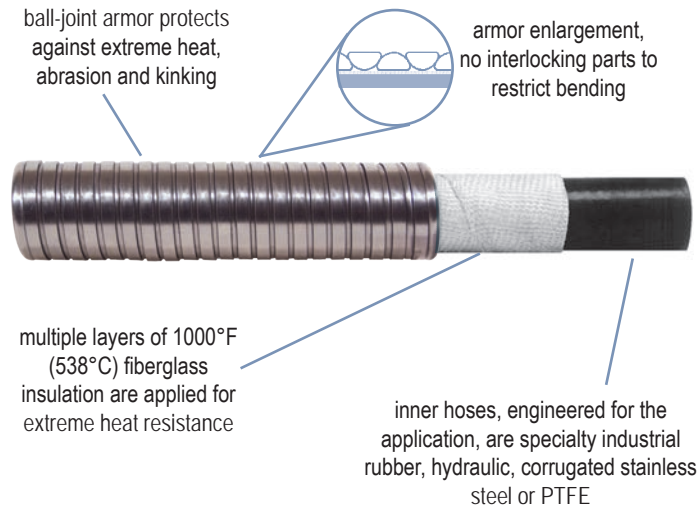

Applications:

- fluid transfer and hydraulic hose assemblies on drilling platforms, blenders and mobile off-highway equipment for supporting oil and gas services in the field

Sizes:

- ¼" through 16" bore with lengths to 120'

Materials:

- armor: galvanized steel or stainless steel

Features:

- extremely flexible armor protects from heat and harsh environments in applications for steam, water, gases, hydraulic fluids, grease and abrasives
- wide selection of inner hoses specific to the demands of the application are industrial, hydraulic, stainless steel or PTFE

Specifications:

- heat resistant insulation to **1000°F (538°C)**
- temperature rating depends on specific applications, consult Dixon®
- a variety of end connections are available

King™ Safety Whipsocks

Applications:

- ideally suited for applications where the media being transferred is under higher working pressures such as air, water, hydraulic and slurry

Sizes:

- ¾" through 6"

Materials:

- wire rope: galvanized carbon steel
- ferrules: aluminum

Features:

- keep the hose under control in the event of a high-pressure hose assembly failure
- dual anchor points secured beyond the fittings eliminate hose whip
- galvanized steel woven stockings extend down the hose to grip securely over a larger area preventing whip, abrasion and wear
- securing both eye-to-rigid or eye-to-eye anchor points reduce whip in the event of a hose connection failure

Specifications:

- contact Dixon® at 877.963.4966 with questions regarding working pressure, available options or custom configurations
- King™ safety shackles are available to anchor the Whipsocks
- be sure the anchoring points are rated for the application



KSW40



Mann Tek Dry Disconnects

Application:

- ensures a quick and spill-free connection in the bulk transfer of hazardous and non-hazardous fluids

Sizes:

- 1" through 6"

Materials:

- stainless steel and aluminum
- rollers: aluminum-bronze on stainless steel shaft
- ball bearings: stainless steel
- protective ring is a specially formulated, weather resistant and electrically conductive rubber compound

Features:

- coupler has built-in swivel
- shaft journal in stainless steel embedded in PTFE eliminates seizure
- riveted piston pin minimizes the risk for failure under extreme pressure conditions



DDC200SS

Bayloc™ Dry Disconnects

Sizes:

- 1½", 2" and 3" couplers and adapters, additional sizes available

Materials:

- stainless steel or aluminum
- for information on chemical compatibility and material selection call Dixon® at 877.963.4966 or visit dixonvalve.com

Features:

- compatible with most cam and groove style dry disconnects, fully interchangeable with Kamvalok® style fittings
- spring loaded sealing device "snaps" closed should the valve become disconnected with the poppet open
- two-piece adapter design allows easy rebuilding of adapters
- EZ Boss-Lock™ cam arms provide security against accidental opening
- automatic closing poppet assembly
- stainless steel handle allows product exposure to corrosive chemicals or wash down service

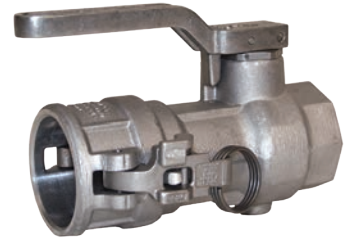

DBC72-200



DBA72-200

Safety Breakaway Couplings

Application:

- used most commonly on tank trucks, railcars and barges to limit the possibility of environmental impact and loss of product resulting from a break in a connection

Sizes:

- 2", 3", 4", 5", 6" and 8"

Materials:

- industrial version: 316 stainless steel or aluminum
- marine version: 316 stainless steel
- seal: FKM (FPM) standard

Features:

- industrial version - fixed point to hose
- marine version - hose to hose
- coupling automatically senses an excessive load, closes the valves and disconnects
- high flow rate / low pressure drop

Specifications:

- working pressure: stainless steel **360 PSI** and aluminum (industrial version) **230 PSI** at ambient temperature **70°F (21°C)**
- available configurations: female NPT, male NPT and 150# flange

Part numbers, 2D drawings and additional information can be found at dixonvalve.com



SBC200SS

VEP & VEP-BOP Series

Thread To Connect Flush Face



VEP Series



VEP-BOP Series

Application:

- used in a variety of drilling rig applications and hydraulic power units where the ability to connect and disconnect under pressure is necessary

Sizes:

- ¼", ⅜", ½", ¾", 1", 1¼", 1½" and 2"

Materials:

- coupler and nipple: steel
- dust cap and plug: aluminum body with steel cable lanyard

Features:

- threaded, no spill design provides the ideal solution for high pressure, high impulse applications
- connect and disconnect under pressure
- patented valve retention system minimizes pressure drop and maximizes connection and pressure performance
- zinc nickel chrome plating provides superior corrosion resistance

Specification:

- interchanges with Stucchi VEP/VEP-HD, DNP PST4/FSI, Holmbury HFT, Parker FET

Approval:

- Blow-out prevention (BOP) version available, fire tested and Lloyd's certified in accordance with API 16D

WS & WS-BOP Series

Heavy Duty Thread To Connect



WS Series



WS-BOP Series

Application:

- extensively used in a variety of oilfield applications

Sizes:

- ¾", 1", 1¼", 1½" and 2"

Materials:

- coupler and nipple: steel or 316 stainless
- dust cap and plug: aluminum body with steel cable lanyard

Features:

- connect under residual pressure
- durable sleeve is cast using a process that provides improved surface finishes, tighter tolerances, and excellent repeatability
- heavy duty "spider" valve holder withstands surge flow and pressurized connections
- seals are easily field replaceable

Specification:

- interchanges with Snap-Tite 75, Hydraulics Inc 5TV, Stucchi VOF, DNP VFF-HD, Faster OGV, Eaton FD85

Approval:

- blow-out prevention (BOP) version available, fire tested and Lloyd's certified in accordance with API 16D

W-Series 7800 Wingstyle Interchange

Application:

- used to connect hydraulic lines on oilfield equipment such as tongs, swivels, and other drill rig applications

Sizes:

- 1/4", 3/8", 1/2", 3/4", 1", 1 1/4" and 1 1/2"

Materials:

- coupler and nipple: brass, steel wing nut
- dust cap and plug: steel body with steel cable lanyard
- nipple mounting flange: steel

Features:

- threaded wing or hex sleeves enable easy connection and disconnection while under residual pressure
- O-ring connected marker is highly visible during connection and helps keep contaminants out of the threads while connected
- coupler has a improved hybrid valve design to reduce pressure drop and turbulence while improving flow performance
- bulkhead mounting kits available
- flanged bonded seal prolongs coupling life and is integral in the reduction of spillage and air inclusion
- couplers and nipples have a full hex body for easy installation

Specifications:

- interchanges with Eaton 5100, Parker 6100, Snap-Tite 78, Safeway S51, Stucchi W



HT-Series ISO 16028 Flush Face Interchange

Application:

- no-spill coupling used to connect hydraulic lines on construction equipment, hydraulic tools, and other hydraulic systems

Sizes:

- 1/4", 3/8", 1/2", 5/8", 3/4", 1", 1 1/2", and 2"

Materials:

- coupler and nipple: steel or 316 stainless
- dust cap and plug: nitrite

Features:

- patented coupler retention system prevents valve stem ejection during surge flow and pressure spike conditions while maximizing flow performance
- high strength laser-cut valve guide in nipple improves valve stability while minimizing flow restriction
- designed to exceed 1,000,000 impulse cycles both connected and disconnect
- bulkhead mountable grooved sleeve for breakaway, multi-plate or blindmate installations
- zinc nickle plating provides superior corrosion resistance

Specifications:

- interchanges with Parker FEM, Eaton FD89, Stucchi FIRG/Series A, Faster FFH, Safeway FF49



ST-Series Flush Face 71 Interchange

Application:

- use in hydraulic applications where a no-spill coupling with higher working pressures and rugged design is required

Sizes:

- 1/4", 3/8", 1/2", 3/4", 1" and 2"

Materials:

- coupler and nipple: steel or 316 stainless
- dust cap & plug: aluminum body with steel cable lanyard

Features:

- flush face valve design minimizes air inclusion during connection and spillage during disconnection
- heavy duty construction for abusive applications
- bulkhead mountable grooved sleeve for breakaway, multi-plate or blindmate installations

Specification:

- interchanges with Snap-Tite 71-Series



T-Series 3000 High Pressure Thread To Connect Interchange

Application:

- designed for high pressure applications such as hydraulic rams and pumps where pressure up to 10,000 PSI is possible

Sizes:

- 1/4" and 3/8"

Materials:

- coupler and nipple: steel or 316 stainless
- dust cap: steel body with steel cable lanyard
- dust plug: steel body with nitrile lanyard
- O-ring: nitrile with TPC-ET back up ring

Features:

- threaded sleeve allows connection and disconnection while coupler and/or nipple are under pressure
- ball valve and poppet valve styles available

Specifications:

- interchanges with Parker/Pioneer 3000, Enerpac C604, Stucchi IVHP, DNP PVM

Enerpac® is a registered trademark of the Enerpac Company



Hydraulic Adapters

- additional adapters and configurations available, call 877.963.4966 or visit dixonvalve.com for more information



45° male NPTF x female NPSM swivel



male 37° flare x male SAE O-ring



JIC male 37° flare x male NPTF



SAE 61 x male JIC



female NPTF x male NPTF branch tee



male flat face x male NPTF

Air & Water Utilities



Air King Couplings
couplers, ferrules and clamps



Pneumatic Couplers
air supply, testing equipment and blow guns



Filters, Regulators, & Lubricators
combination units, repair kits



Gauges
digital, liquid filled and dry



Fire Hose and Reels
nozzles, racks and safety equipment



PTFE Assemblies
hose, couplings and fittings

Part numbers, 2D drawings and additional information can be found at dixonvalve.com

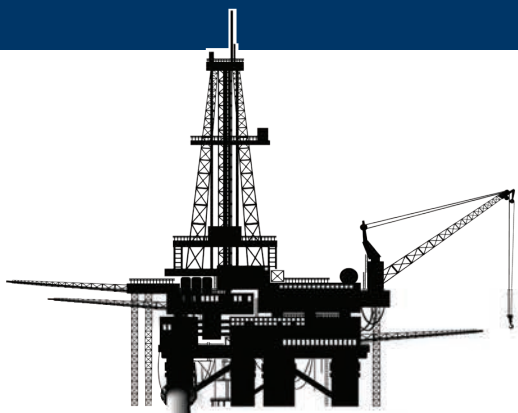

EXPLORATION/ PRODUCTION

Petro•chem•ical

noun

Any chemical derived from petroleum or natural gas.

Many countries, many cultures, but the same Petrochemical Life Cycle applications using DIXON products for safe and reliable fluid transfer.

Popular brands include... Boss, Bayco, Holedall, King, and more...



TRANSPORTATION



REFINING



TRANSPORTATION

1



Exploration and Production

2



Refining

- Boss™ Low Pressure System Products
- Frac Fittings
- King Crimp System
- Hammer Unions
- Control Valves
- Holedall Couplings
- Tank Truck and Rail Car/API Fittings & Assemblies

- Dry Break Couplings
- Cam & Groove
- Dry Disconnects
- Ground Joint Systems
- Valves
- API Fittings

THE PETROCHEMICAL LIFE CYCLE



Terminal

- Overfill Protection
- Loading/Unloading
- Adapters
- Vapor Elbows
- Swivels
- Tank Truck and Rack Fittings
- Nozzles



Scan for more information on the petrochemical life cycle

Dixon®, founded in 1916, is a premier manufacturer and supplier of hose couplings, valves, dry-disconnects, swivels, and other fluid transfer and control products. The company's global reach includes a wide range of products for numerous industries including petroleum exploration, refining, transportation, chemical processing, food & beverage, steel, fire protection, construction, mining and manufacturing. Dixon's strategic objective is to create solutions that make products safer, leak-free, longer lasting, and always available.

dixonvalve.com • *Customer Service:* 877.963.4966



The Right Connection®

Dixon®

800 High Street, Chestertown, MD 21620

ph 877.963.4966

fx 800.283.4966

